

Features

- Control 2 accessories on the vehicle via ISAAC Instruments' DRU9xx; door locks, anti-theft system, etc.
- Operating indicator LED
- Easy connectivity to ISAAC Device Network (IDN)
- Rugged enclosure and small size
- Weather resistant enclosure and connectors

Description

The module IDNRLY is used to activate two relays 1A @ 24VDC/120AC: door locks, anti-theft system, etc.

The IDNRLY is controlled directly by an ISAAC Instruments' Recorder via ISAAC Device Network (IDN).

The module has 2 CAN ports allowing to extend the IDN with additional modules or to terminate the IDN using a termination resistor (IDNTR1).



Installation

Setup:

- Connect IDNRLY (Port « CAN IN ») to one of available ports of the IDN
- Make sure to connect the termination resistor (IDNTR1) if IDNRLY is at the end of IDN
- Connect the relay outputs following your application (common, normally closed, normally open)
- Route the cable at least 20cm (8") away from high interference electrical devices, such as: ignition coils, plug leads, high-current leads, high emission electronic modules or antennas
- Refer to page 3 for an example of installation
- Refer to the section «using the system» (page 2) for more details

Software configuration:

CAN Port Activity: ISAAC Device Network

CAN bit rate: 500 Kbit/s

Using the system:

- **Connectivity diagram (top view) :**

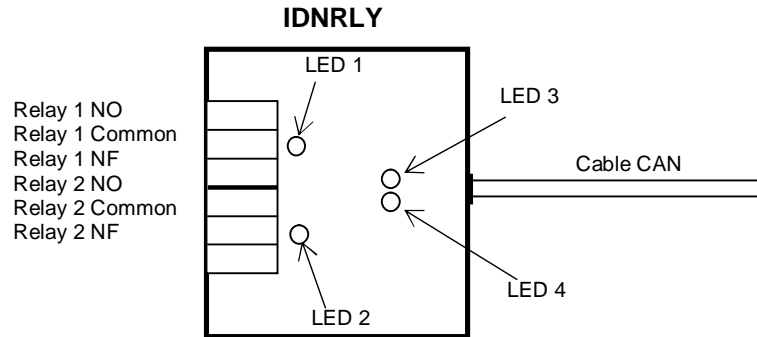

- **Functionality Diagram:**

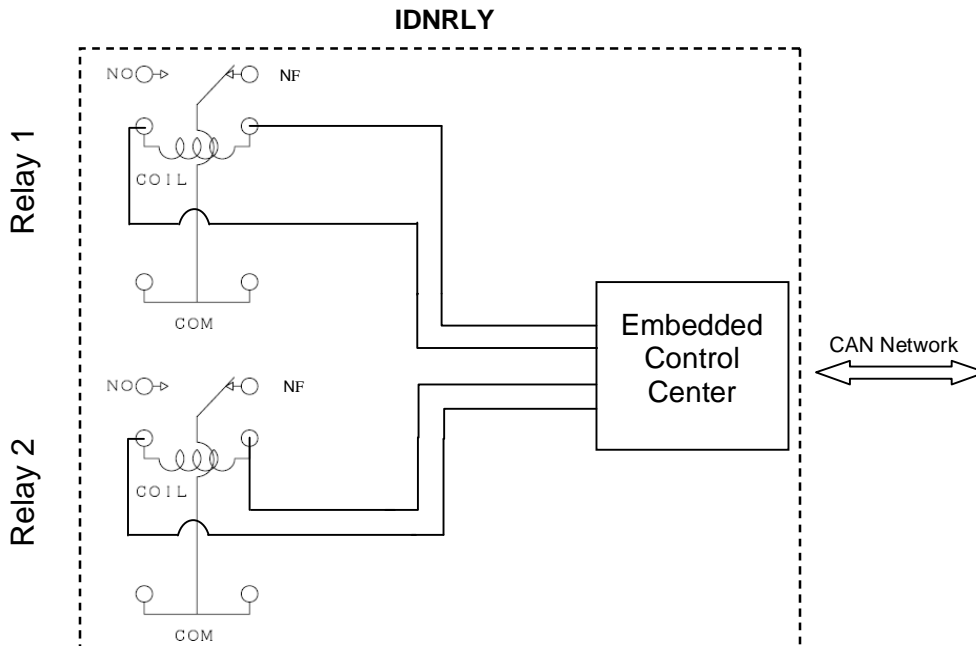

- **Description of the LED status:**

| LED # | Color | Status |
|-------|--------------|--|
| LED 1 | Red OFF | Relay #1 is active Relay #1 is inactive |
| LED 2 | Red OFF | Relay #2 is active Relay #2 is inactive |
| LED 3 | Green | CAN communication is functional |
| LED 4 | Blinking Red | CAN communication error |

Specifications

| Description | Symbol | Min. | Typ. | Max. | Unity |
|----------------------------------|--------------|-----------|------------|----------|---------|
| Power requirements | | | | | |
| Power supply voltage | V_{in} | 11 | | 30 | V |
| Current | I_{in} | | 50 | | mA |
| Communication interface | | | | | |
| Type | | HS CAN | | | |
| Speed | V_{can} | | 500 | | Kbps |
| Characteristics of relay contact | | | | | |
| Current | I | | 1 | | A |
| Voltage | V_{dc} | | 24 | 30 | VDC |
| | V_{ac} | | 120 | 120 | VAC |
| Power | P_{max} | | | 24 | W |
| Minimum load | I_{min} | | 30 | | mA |
| Maximum activation rate | | | | | |
| With load | R_{wload} | | | 30 | act/min |
| Without load | R_{noload} | | | 300 | act/min |
| Lifetime without charge | | | | | |
| With load | L_{wload} | | 100 000 | | act. |
| Without load | L_{noload} | | 5 millions | | act. |
| Résistance | R | | 50 | | MOhm |
| Environnement | | | | | |
| Operating temperature | T_{Oper} | -40 (-40) | | 80 (176) | °C (F) |
| Storage temperature | T_{Stor} | -40 (-40) | | 80 (176) | °C (F) |
| Humidity | | | 100% | | |
| Mechanical properties | | | | | |
| Height | H | | 50 (2) | | mm (in) |
| Width | W | | 50 (2) | | mm (in) |
| Depth | D | | 16 (0.63) | | mm (in) |

Typical installation of ISAAC Device Network (IDN)

